



BackyardXpo

Outdoor Living Xperience



OUTDOOR KITCHENS

OUTDOOR KITCHENS... BUILT TO LAST

LIFETIME PROTECTION

- Galvanized steel support structure, stronger than aluminum and engineered to support the heaviest counter-tops
- Non-combustible fibrous cement exterior and floor panels are moisture and insect resistant to guarantee long outdoor life
- Sealed and finished interior cabinetry provides clean, usable storage space and is moisture and insect resistant
- Full bonding of exterior panels in this uni-body construction system provides lifetime strength and durability
- Commercial textured exterior finish is 100% acrylic polymer, delivering long term moisture resistance, durability and easy cleanup
- Anti-Bacterial/Anti-Corrosion interior finish gives you peace of mind with added corrosion protection and easy maintenance
- Natural Stone or porcelain tile counter-top with quartz grout offers durability and long lasting beauty thanks to their resistance to mold, mildew and food stains

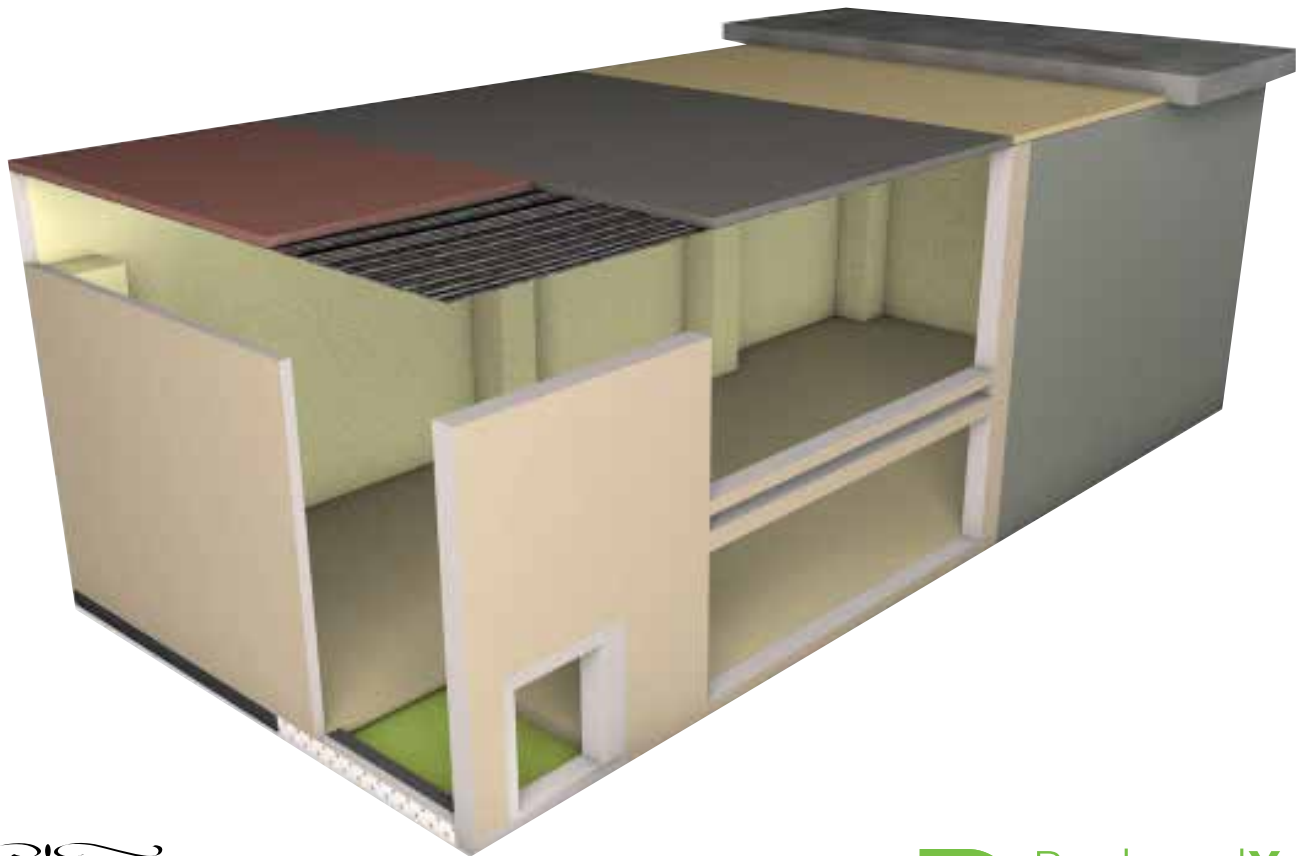



NO SHORTCUTS...
THAT'S WHAT IT TAKES TO GIVE OUR CUSTOMERS LONGEVITY & RELIABILITY IN AN OUTDOOR KITCHEN.

CABINET OPTIONS

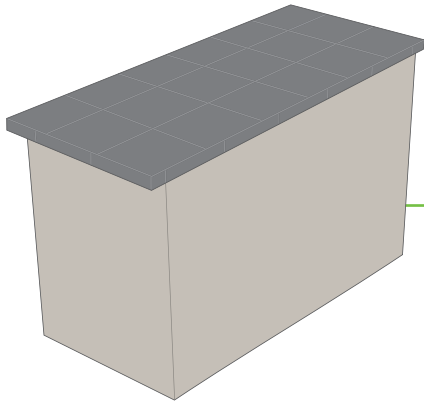

CABINET WITH COUNTER-TOP

Natural stone or porcelain tile counter-top with 1.75" overhang

Size - 28" x 36" height

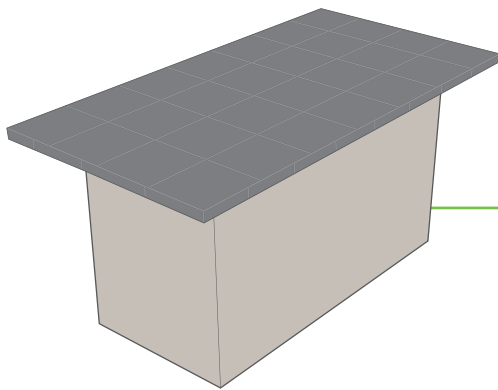

CABINET WITH EXTENDED COUNTER-TOP:

Natural stone or porcelain tile counter-top
Priced by the linear foot x 12" width

Size - 28" x 36" height

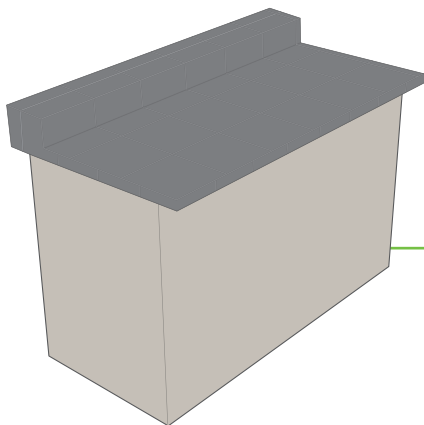

CABINET WITH DELUXE DEEP BACKSPLASH:

Natural stone or porcelain tile counter-top with 1.75" overhang

Backsplash 6" tall x 7" deep

Size - 31" x 36" height

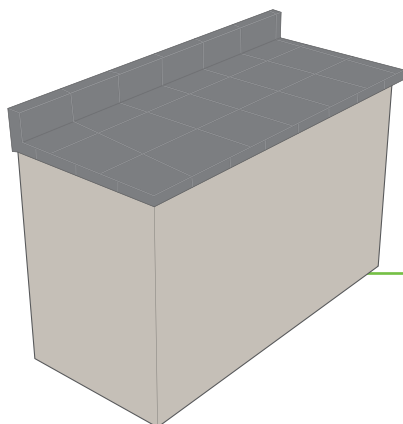

CABINET WITH STANDARD BACKSPLASH:

Natural stone or porcelain tile counter-top with 1.75" overhang

Backsplash 6" tall x 3" deep

Size - 28" x 36" height

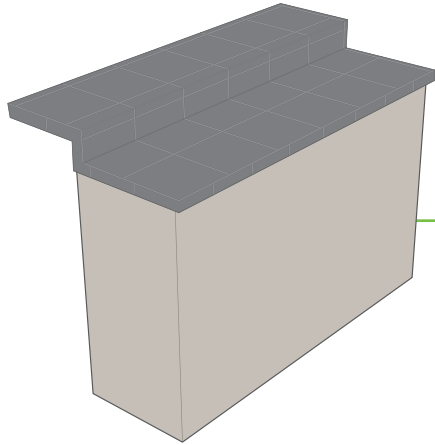

2 TIER BAR WITH BACKSPLASH:

Natural stone or porcelain tile counter-top with 1.75" overhang

Size - 20" x 42" height

Total depth 32" with counter-top

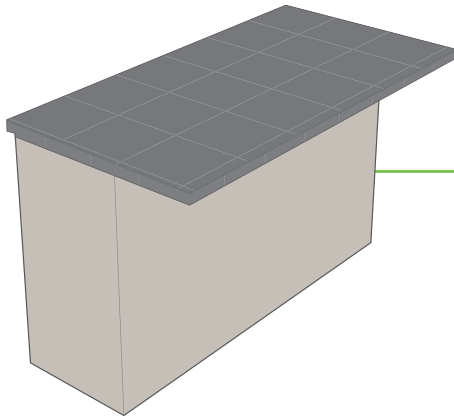

FLAT BAR WITH FLAT COUNTER-TOP:

Natural stone or porcelain tile counter-top with 1.75" overhang

Size - 20" x 42" height

12" counter-top extension

Total depth 32" with counter-top

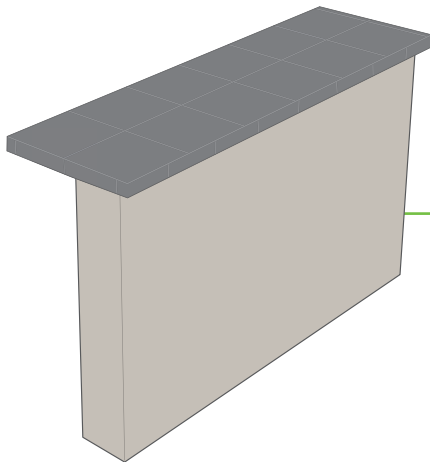

SMART BAR:

Natural stone or porcelain tile counter-top with 1.75" overhang

Size - 7" x 42" height

12" counter-top

Total depth 19" with counter-top

FINISH OPTIONS FOR ALL CABINETS:

- Fully furnished cabinet with acrylic texture and counter-top
- Unfinished cabinet with counter-top
- Finished cabinet with acrylic texture - NO COUNTER-TOP
- Unfinished cabinet - NO COUNTER-TOP / NO TEXTURE

CABINET ACCESSORIES

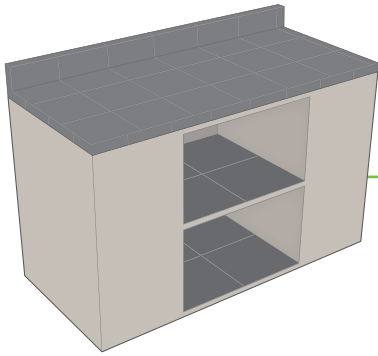

OPEN SHELVES:

24" width x 30" height x cabinet depth - 1 shelf

Finish options:

- Tiled floor, acrylic inside edges
- Acrylic only
- Unfinished

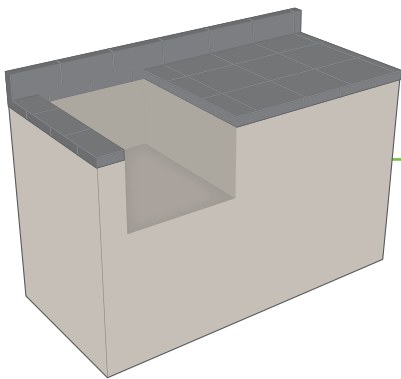

DROP IN OPENINGS:

20" width x 15" depth or to need
Suitable for Kamado or Power Burner

Finish options:

- Fully tiled interior
- Tiled floor, acrylic inside edges
- Acrylic only
- Unfinished

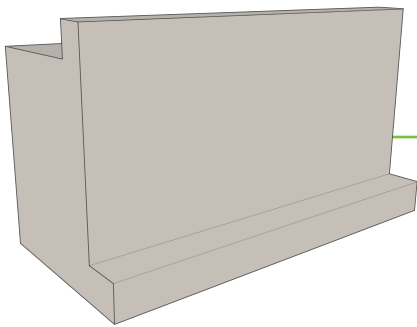

FOOT REST

6" tall x 6" width

Finish options:

- Tiled
- Acrylic only
- Unfinished



LED LIGHTING

OUTLETS:

Both exterior and interior electrical outlets are available



EXTERIOR OUTLET



INTERIOR OUTLET

YOUR OUTDOOR KITCHEN PROJECT IS AS EASY AS 1-2-3

1 CHOOSE CABINET:

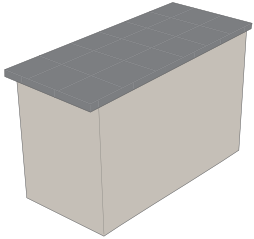

STANDARD
CABINET

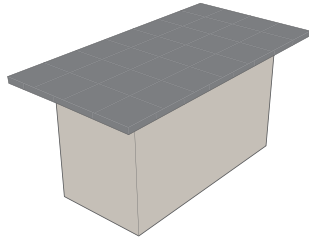

CABINET WITH
EXTENDED
COUNTER

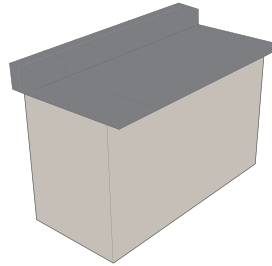

DELUXE
BACKSPLASH
7" DEPTH X 6" HEIGHT

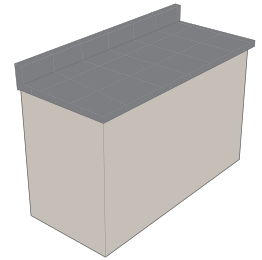

STANDARD
BACKSPLASH
3" DEPTH X 6" HEIGHT

2 CHOOSE BAR:

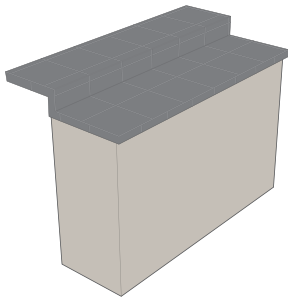

2 TIER BAR WITH BACKSPLASH

- 20" base
- 12" overhang

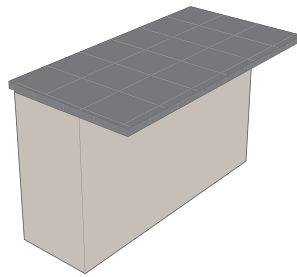

FLAT BAR

- 20" base
- 12" overhang

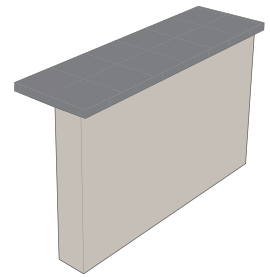

SMART BAR

- 7" base
- 12" overhang
- 19" total counter-top

3 CHOOSE FINISH LEVEL:

ACRYLIC TEXTURED CABINETS

TILE COUNTER-TOP

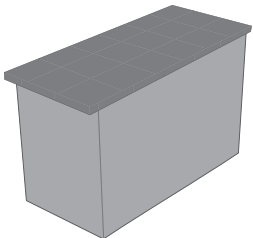

NO COUNTER-TOP

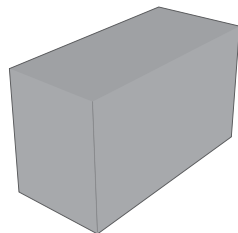

UNFINISHED CABINETS

TILE COUNTER-TOP

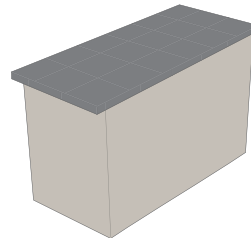

NO COUNTER-TOP

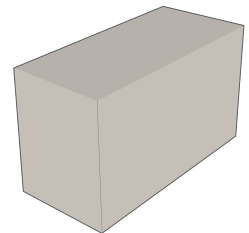

WITH THESE 7 COMPONENTS AND 4 LEVELS OF FINISH, YOU CAN RELY ON US TO:

- Meet your needs on space and purpose
- Maintain cost control with no overages or surprises
- Install most projects in less than 2 hours
- Exceed your expectations

OUTDOOR KITCHEN PACKAGES

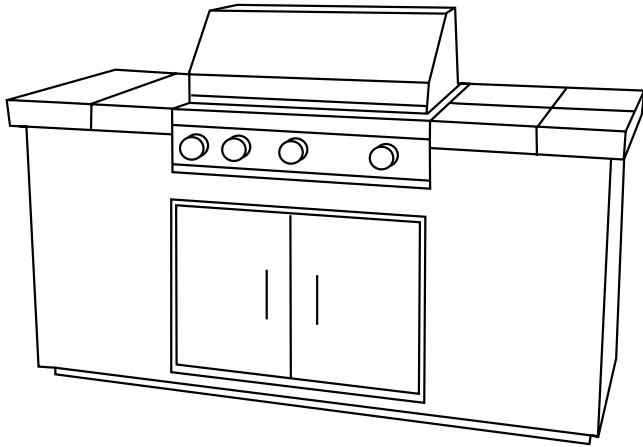

LARGO

- 6' cabinet with acrylic texture and stone tile counter
- 32" Sizzler grill
- Double doors

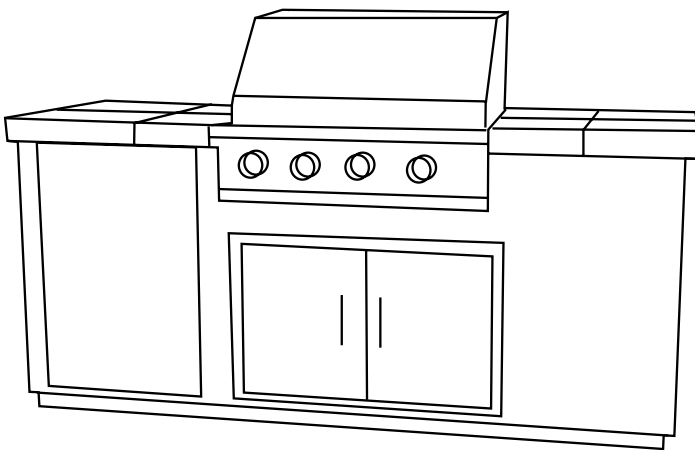

KEY WEST

- 7' cabinet with acrylic texture and stone tile counter
- 32" Sizzler grill
- Double doors
- Refrigerator

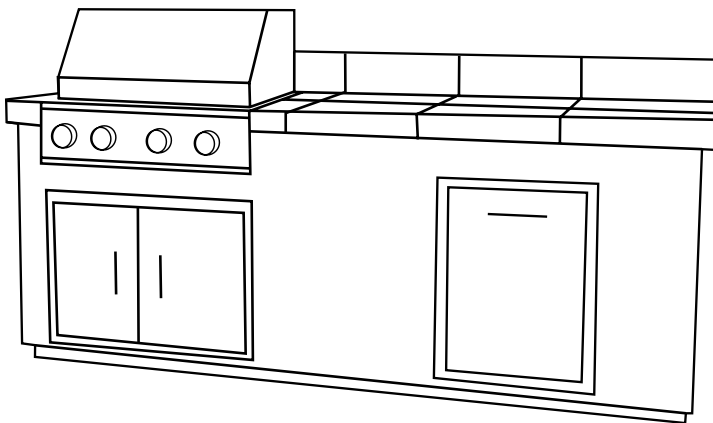

VENICE

- 8' cabinet & backsplash with acrylic texture and stone tile counter
- 32" Sizzler grill
- Double doors
- Trash drawer

*Finished cabinets include toe kick.

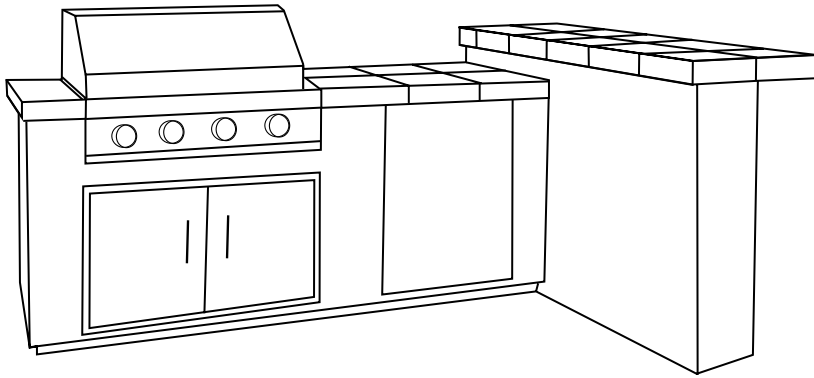

ANNA MARIA

- 12' cabinet & bar with acrylic texture and stone tile counter
- 6.5' cooking cabinet plus 5.5' Bar
- 32" Sizzler grill
- Double doors
- Refrigerator

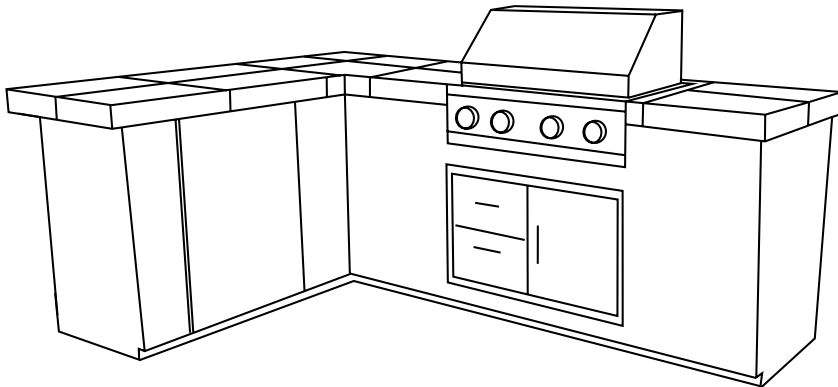

SEBASTIAN

- 13' L-shaped cabinet with acrylic texture and stone tile counter
- 32" Sizzler grill
- Door/drawers
- Refrigerator

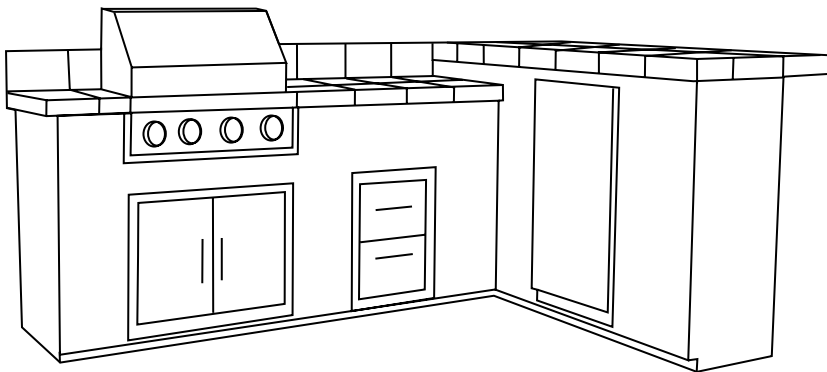

PALM BEACH

- 15' L-shaped cabinet with acrylic texture and stone tile counter
- 7' cooking cabinet plus 8' bar
- 32" Sizzler grill
- Double doors
- Double drawers
- Refrigerator



BackyardXpo

Outdoor Living Xperience

OUTDOOR CABINET FINISH OPTIONS

ACRYLIC COLORS:



ACRYLIC TEXTURES:



Sand Finish S-10

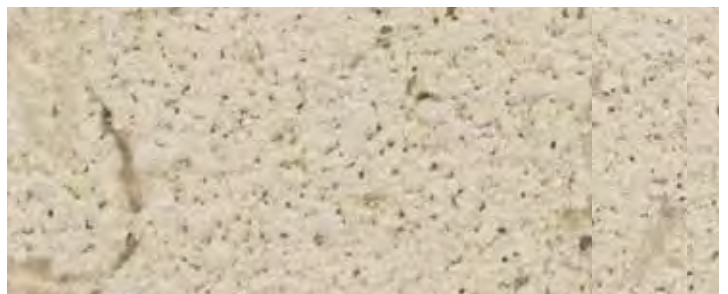

Texture Finish T-20

NATURAL STONE VENEERS:



Scabos



Ivory/Natural



Russian Gold



Honey Dew



Silver



Golden Sunrise



Mondrian Honed



Honey Dew Pencil



Oceana



Glacier

TRAVERTINE COUNTER-TOPS:



Mocha Honed

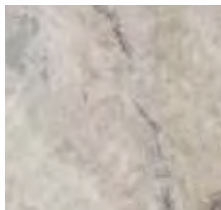

Silver Honed



Classic Honed

MARBLE COUNTER-TOPS:

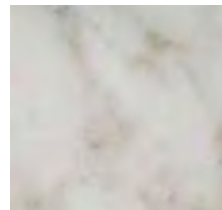

White Marble Polished



Kalta Fiore Polished



Milano Beige Polished

GRANITE COUNTER-TOPS:



Black Galaxy



Uba Tuba



New Venitian Gold



Absolute Black

PORCELAIN COUNTER-TOPS:



White

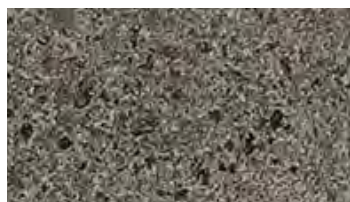

Charcoal



Ivory



Fawn

*Other porcelain colors available

If you prefer supplying your own material, counter-top, appliances and labor, we are happy to provide our factory-built custom cabinets based on your choices.



EQUIPMENT OPTIONS



PREFERRED PARTNERS

BackyardXpo Kitchens can be customized to accommodate any appliances. However, we highly recommend going with appliances and accessories from our Preferred

SUMMERSET PROFESSIONAL GRILLS

- Broad product selection
- Excellent product quality
- Lifetime parts warranty
- Designed for any budget



PRIMO CERAMIC GRILLS

- Patented oval shapes offers higher cooking versatility and better efficiency than competitors



- Only "Kamado Style" ceramic grill made in America

DESIGN RENDERING SERVICES

NOT SURE WHERE TO START OR
HOW TO MAKE THE MOST OF YOUR OUTDOOR KITCHEN SPACE?

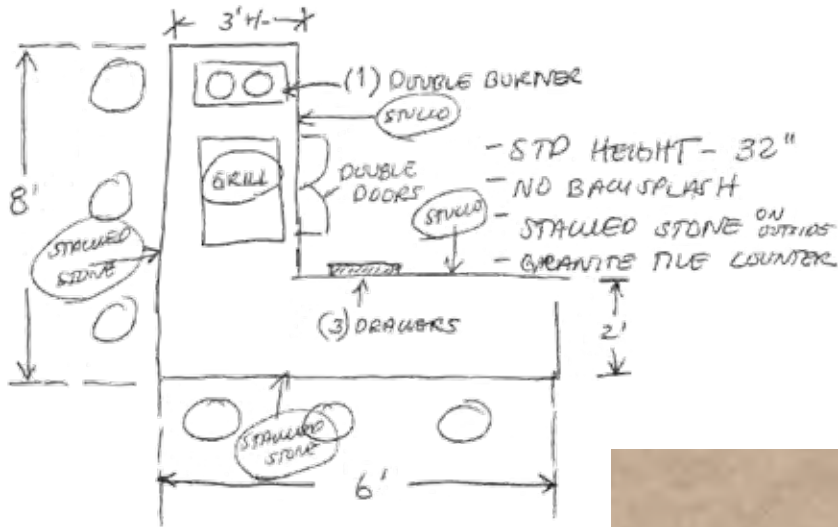

WE CAN TAKE
YOUR IDEA...

AND MAKE IT
A REALITY!

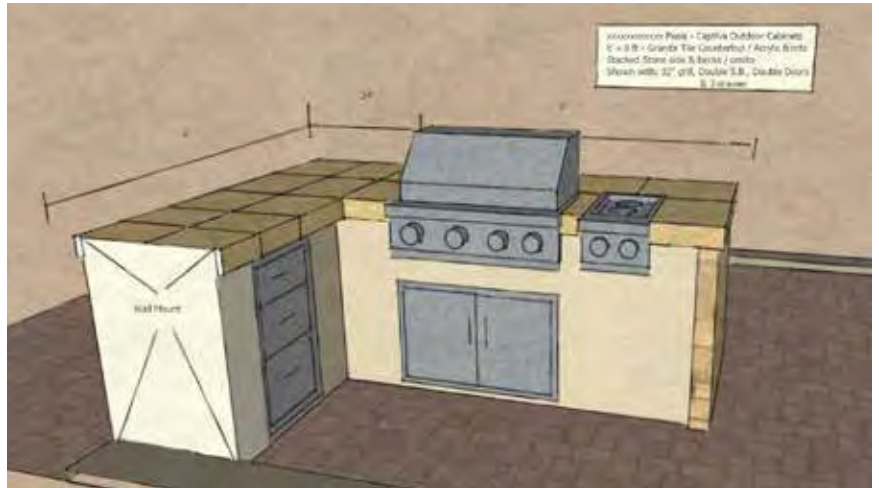

LET OUR YEARS OF EXPERIENCE HELP YOU GET
THE OUTDOOR KITCHEN OF YOUR DREAMS.

Just send us your sketch and we will provide a design consultation and 3D rendering.

Simply email a sketch to backyardxpo@teamhorner.com.

From this, we will produce a rendering for your approval!

With help from BackyardXpo, it's easy to make outdoor living dreams come true.





Acrylic textured cabinet plus 2 tier bar with backsplash and stone tile counter-top



Stone veneer exterior with solid granite counter-top



Stone veneer exterior with solid granite counter-top



Stone veneer exterior with solid granite counter-top

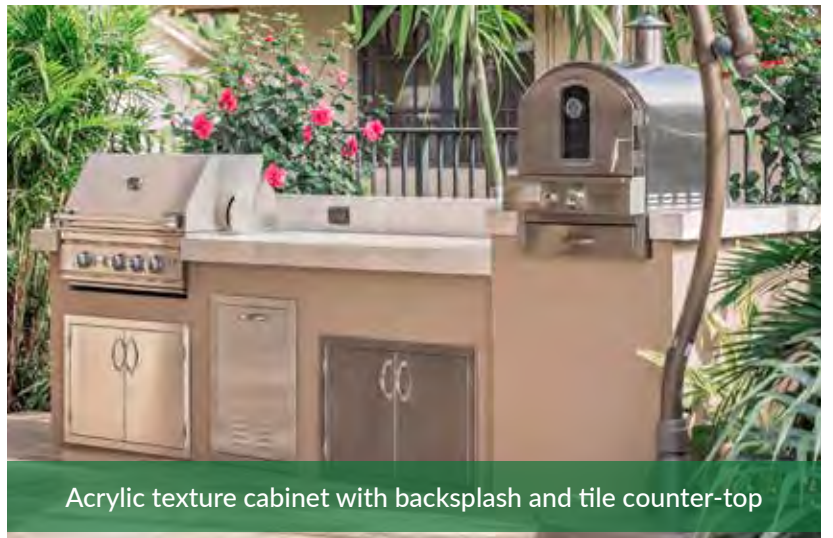

Acrylic texture cabinet with backsplash and tile counter-top



U-shaped cabinet with stone veneer exterior and tile counter-top



Glass tile exterior with solid granite counter-top and backsplash



Hardie plank exterior siding with solid granite counter-top

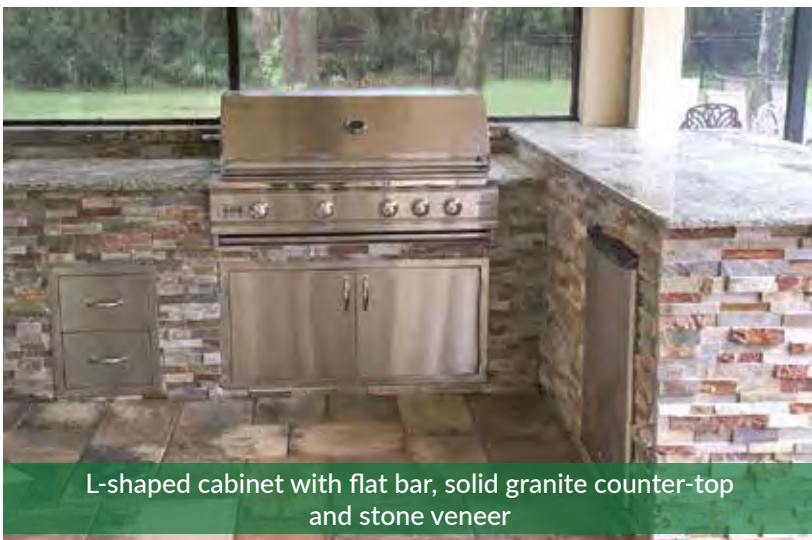

L-shaped cabinet with flat bar, solid granite counter-top and stone veneer

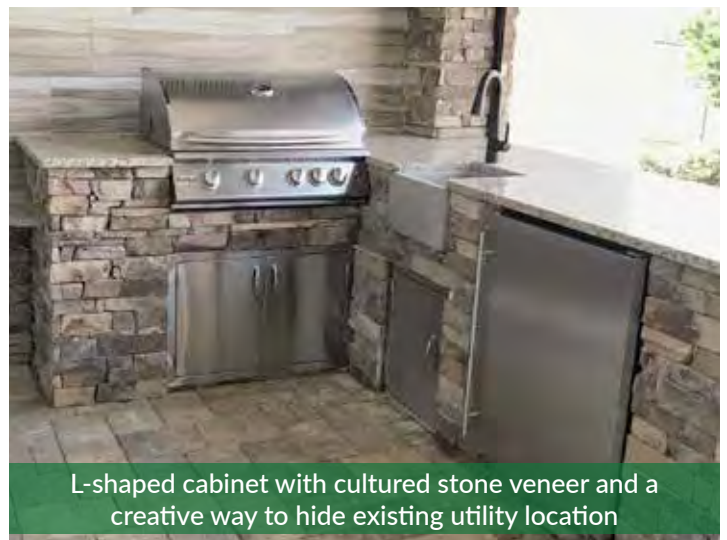

L-shaped cabinet with cultured stone veneer and a creative way to hide existing utility location

